

(No Model.)

C. M. CONRADSON.
CHUCK FOR SCREW MACHINES.

No. 489,933.

Patented Jan. 17, 1893.

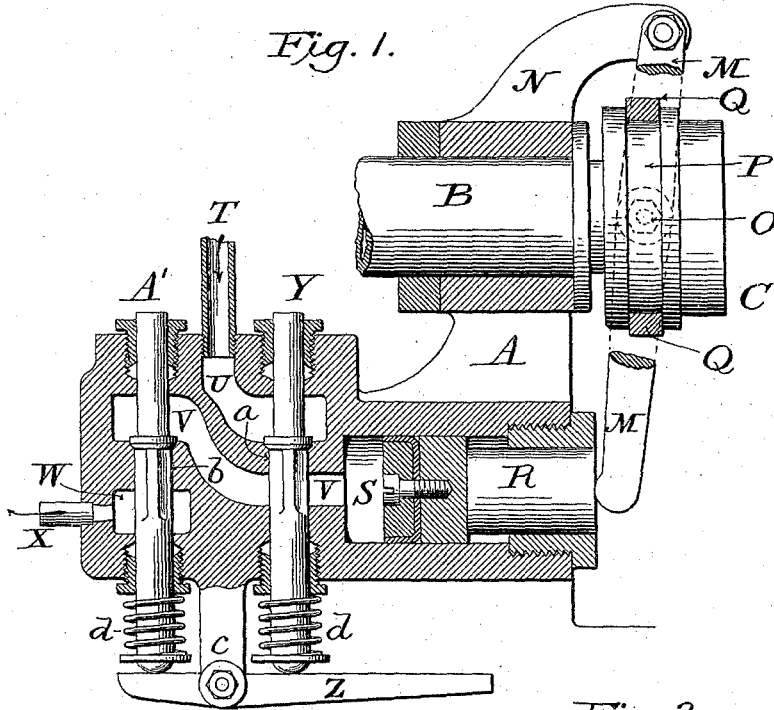

Fig. 2.

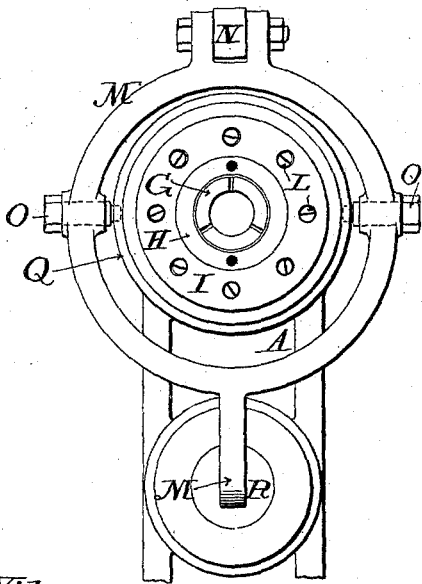
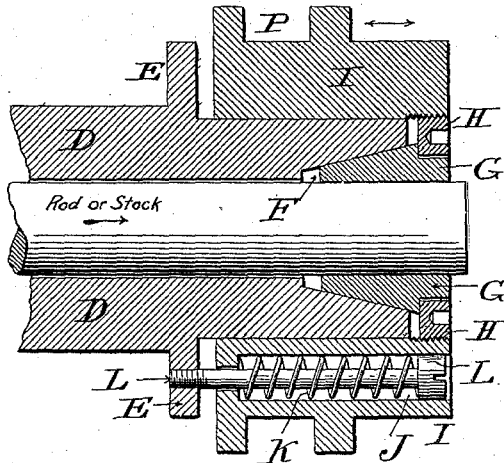

Fig. 3.



CONRAD M. CONRADSON,
Inventor,

Witnesses:

James F. Duhamel
Horace A. Dodge.

by Dodge & Sons,
Attys.

UNITED STATES PATENT OFFICE.

CONRAD M. CONRADSON, OF MADISON, WISCONSIN.

CHUCK FOR SCREW-MACHINES.

SPECIFICATION forming part of Letters Patent No. 489,933, dated January 17, 1893.

Application filed March 24, 1892. Serial No. 426,251. (No model.)

To all whom it may concern:

Be it known that I, CONRAD M. CONRADSON, a citizen of the United States, residing at Madison, in the county of Dane and State of Wisconsin, have invented certain new and useful Improvements in Chucks for Screw-Machines, of which the following is a specification.

My invention relates to chucks or work-holders, and has reference more particularly to that class of chucks used on screw making machines, although the invention is obviously applicable to other classes and styles of machinery.

In the accompanying drawings,—Figure 1 is a side elevation partly in section of my improved chuck, and the mechanism for operating the same as applied to the head stock of a screw making lathe; Fig. 2, front end view of the same; and Fig. 3, an enlarged longitudinal sectional view through the chuck proper.

A indicates the head stock of a lathe, B, the hollow arbor or mandrel, and C the chuck secured to the end thereof. This chuck comprises a main body or tubular stem D, having at a distance from its ends a collar E, and at its outer end a conical socket F, as clearly shown in Fig. 3. Mounted in this socket F is a conical split ring G made up of two or more sections and having its outer end shouldered or reduced slightly to receive a ring H which is threaded externally as shown in Fig. 3 to engage the sliding shell or case I of the chuck. This sliding shell or case I is provided with a number of sockets J extending parallel with the axis of the arbor, and in each of these sockets I mount a coiled spring K, which bears at one end against the base of the socket and at the opposite end against the head of a screw or bolt L whose inner end, passing through the bottom wall of the socket, screws into the collar or flange E of the tubular stem D. These springs tend to draw the sliding body I rearwardly with reference to the tubular stem, and as this body I moves rearwardly it will, through the collar H which is connected thereto, cause the slotted conical collar or ring G to tightly grasp the rod or other article passing through the hollow stem of the chuck. It will therefore be seen that the grip action in this case is due entirely and solely to the action of the springs, and as there is quite a large number of these springs

they will act effectively to clamp the rod in position. In order to release the rod which passes through the tubular stem it is necessary to move the shell I outward against the pressure of the springs so that the sections of the slotted block G may be freed to permit the rod to be readily passed through the tubular stem D. In order to thus move or actuate the shell I, I employ a lever M which is pivoted to an arm N projecting from the upper side of the head stock. This lever M is made in the form of a yoke to encircle the sliding chuck shell I and is provided with a ring Q which is fitted into a circumferential groove P formed in the shell I as clearly shown in Fig. 1. The ring Q is pivotally connected with the yoke or lever M by means of the pivots or studs O, as shown in Fig. 2. The lower end of the yoke or lever M comes directly opposite the outer end of a piston R which is mounted in a cylinder S, formed, in the present instance, in the head stock of the machine; the said piston being designed to be actuated by air, water, gas, steam or other fluid admitted to the cylinder through the inlet pipe T.

The inlet pipe T communicates with a chamber U which communicates through a passage *a* with a chamber V, which latter communicates directly with the cylinder S. The chamber V also communicates with a chamber W by means of a passage *b* and the said chamber W is connected to the outlet pipe X as clearly shown in Fig. 1.

Y indicates a vertically moving valve which has its seat in the passage *a*, and when raised, opens communication between the chambers U and V,—the lower end of said valve Y being supported upon a lever Z pivoted to an arm or bracket *c* projecting from the frame of the machine. A coiled spring *d* encircles the lower end of the valve-rod and by bearing at opposite ends against the lower stuffing box and a washer or collar on the valve rod, tends to hold the valve to its seat. When, therefore, it is desired to actuate the piston R it is only necessary to raise up the rear end of the lever Z and thereby raise the valve from its seat. This being done, the fluid finds its way through the pipe T, chamber U and passage *a* into chamber V and from this chamber into the cylinder. The

fluid then acts upon the rear end of the piston R, projects the same from the cylinder and carries the yoke or lever M forwardly and with it the shell I of the chuck.

5 In order to provide for the inward or return movement of the piston I employ a second valve, A' which passes vertically through the passage *b* and is, like the valve Y, provided with a coiled spring *d*. The lower end
10 of this valve A' also rests upon one end of the lever Z, and hence it is only necessary to raise that end of the lever to cause the valve to rise from its seat. As soon as the valve rises from
15 its seat the fluid passes from the cylinder into the chamber V down through the passage *b* into chamber W and out through the pipe X, the pressure of the springs K in the chuck being sufficient to throw the lever and piston
20 back into the cylinder and force the fluid from the cylinder.

It is obvious that the chuck represented in Fig. 3 may be actuated by means other than those shown in Fig. 1; and it is also clear that the construction and arrangement of the
25 valve mechanism shown in Fig. 1 can be used in combination with other styles of chuck. For instance, those chucks in which the lever or yoke M would serve to grip or tighten the
30 jaws instead of releasing them as in the present instance.

While I have for convenience shown the valve chambers and the cylinder as mounted directly in the head stock of the lathe, this is not essential.

35 I am aware that a chuck has been patented in which the hollow stem was fashioned into a piston and mounted within a rotating cylinder, and to such construction I make no claim.

40 Having thus described my invention, what I claim is:—

1. In a chuck, the combination with a hollow stem having a conical socket at its outer end, of a conical collar seated in said socket,
45 a sliding shell mounted upon the tubular stem, springs serving to urge the shell backward and to force the conical block against the article to be held, and means for moving the shell forward.

50 2. In combination with a tubular body D having a conical socket F at its outer end, the conical slotted collar G mounted in the socket, a ring H applied to the face of said collar, a sliding shell mounted upon the body
55 of the chuck and connected with the ring H,

a series of bolts L mounted in suitable sockets in the shell I and secured to the body of the chuck, and coiled springs K encircling said bolts and serving to move the shell I inwardly or backward upon the main body of
60 the chuck.

3. In combination with the tubular body D, the conical collar G, the sliding shell I, the springs serving to actuate the shell and force the collar against the article, and the yoke or
65 lever M for moving said shell I outward against the force of the spring, all substantially as shown and described.

4. In combination with the chuck provided with a series of jaws, springs serving to actuate said jaws and cause them to bind upon
70 the article to be grasped, and fluid pressure mechanism to overcome the tension of said springs and release the jaws.

5. In combination with a sliding portion or
75 member of a chuck, an independent fluid pressure mechanism, substantially as shown and described, for actuating said sliding member.

6. In combination with a chuck and the
80 actuating lever or yoke M, a cylinder provided with a piston R to act upon the end of the yoke or lever, a valve Y for admitting fluid under pressure to said cylinder, and an outlet valve A', all combined and arranged for
85 operation, substantially as described.

7. In combination with a chuck and its operating lever M, a cylinder S provided with a piston R, an inlet chamber U, an outlet chamber W, an intermediate chamber V connected
90 with the cylinder and communicating with the chambers U and W respectively, by passages *a* and *b*, a valve Y mounted in the passage *a*, and a valve A' mounted in the passage *b*, all substantially as shown and de-
95 scribed.

8. In combination with a chuck and its actuating lever M, a cylinder S provided with piston R, an inlet valve Y and an outlet valve
100 A', springs encircling the valve stems and serving to hold them to their seats, and a lever Z upon which the valves rest, all substantially as shown and described.

In witness whereof I hereunto set my hand in the presence of two witnesses.

CONRAD M. CONRADSON.

Witnesses:

JOHN F. LYDON,
W. R. BAGLEY.